

# Ship-Rolling Motion Adaptive LED 집어등 시스템의 개발에 관한 선행 연구

## Preliminary Study on Development of Ship-Rolling-Motion-Adaptive LED Fishing Lamp System

허민<sup>1</sup>, 이학<sup>2,#</sup>, 오재윤<sup>3,#</sup>  
Min Heo<sup>1</sup>, Hak Yi<sup>2,#</sup>, and Chae Youn Oh<sup>3,#</sup>

<sup>1</sup> 전북대학교 로스알라모스-한국공학연구소 (LANL-Engineering Institute Korea, Chonbuk National University)

<sup>2</sup> 경북대학교 기계공학부 (School of Mechanical Engineering, Kyungpook National University)

<sup>3</sup> 전북대학교 기계시스템공학부 (Division of Mechanical System Engineering, Chonbuk National University)

# Corresponding Author / E-mail: ochy@jbnu.ac.kr, TEL: +82-63-270-2377, FAX: +82-63-270-2377

E-mail: yihak@knu.ac.kr, TEL: +82-54-950-7541, FAX: +82-54-950-7541

KEYWORDS: Fishing lamp (집어등), Light emitting diode (발광 다이오드), Irradiation region (발광 지역), Tilt angle sensor (기울기 각도 센서), Differential amplification (차동 증폭)

*This paper presents a preliminary study on the development of a Light-Emitting Diode (LED) fishing lamp system that can maintain a stationary irradiation region despite ship rolling motions. The proposed system is composed of three modules which include a main control module, a fishing lamp module, and a sensor module. The main control module collects both the operating condition setting of the fishing lamp via the input panel and the tilt angle information of a fishing boat from the sensor module. It provides the conditions and information to the fishing lamp module for controlling the LED modules that maintain a stationary irradiation region. One fishing lamp module is composed of 22 LED modules, a lamp controller, and a temperature sensor. The sensor module is used for measuring the tilt angle of the fishing boat. Tests were carried out to verify the reliability of the LED module driver and the sensor module. The tests showed that the LED modules were reliably controlled, in accordance with the rolling motion of a fishing boat.*

Manuscript received: March 15, 2017 / Revised: April 30, 2017 / Accepted: May 2, 2017

### 1. Introduction

Over past two decades, there have been many significant researches that a fishing lamp on jigging fishing boats attracts a variety of photo-tactic fishes.<sup>1</sup> Metal halide lamps on jigging fishing boats have historically been used for reaching an efficient operation of a nighttime fishery because they output high intensity light.<sup>1,2</sup> However, metal halide lamps output a large amount of ultraviolet light which can result in skin damage for the fisherman, and the high intensity UV light can cause vision damage as well.<sup>3</sup>

To this end, a Light Emitting Diode (LED) fishing lamp has recently been developed as an alternative to metal halide lamps for

this application.<sup>4,5</sup> LEDs are suitable because they don't have the downsides of metal halide lamps; they only emit light or electromagnetic waves in the visible spectrum. In addition, there are benefits to energy efficiency simply because of the operating nature of LEDs.<sup>6</sup> In case of 12 m × 5 m boat, illuminance of the LED fishing light attractor during the nighttime operation was investigated as to produce approximate 470 lux. Furthermore, it shows 15 to 17% less consumption gas power than their counterparts, respectively.<sup>7</sup>

However, the main downside to using LEDs for fishing lamps irradiated region to shift. The movement of the irradiation region would result in contrast fluctuation in the irradiated region which

would negatively affect the ability to attract photo-tactic fish because fish school significantly attracts to a stationary irradiation angle emitted from a lamp light on a fishing boat.<sup>3</sup>

In previous studies, in order to cope with the contrast variation due to the inclination to the left of right of a fishing boat, a counterweight was attached to the fishing lamp to adjust the light irradiation angle,<sup>8</sup> and a motor was used to rotate the fishing lamp to compensate for the light irradiation angle.<sup>8,9</sup> In addition, some balance studies on sea wave are investigated to collect balance information on a variant sea wave.<sup>9,10</sup> However, such attempts meant that the fishing lamp was structurally more complicated. As the fishing lamps became more structurally complicated, the weight and the facility cost increased.

This study as a preliminary research on LED fishing lamp system on a board, shows the development of an LED fishing lamp system that can maintain a stationary irradiation region using only an electronic control system. Since the proposed LED fishing lamp system does not have any mechanisms, it is not structurally complicated and is lightweight as a result. This system is controlled by a sensor-based control scheme (on/off switch control).

**2. LED Fishing Lamp System**

Jigging fishing boat has an installed lamp systems in rows along boat length. When a fishing boat is in a roll motion, the angle of the light irradiated by the fishing lamp mounted to the fishing boat will continuously change. In this study, it is assumed that an LED fishing lamp is installed at a 3.3 m height above sea level and a fishing boat sits vertically. Given that all LED module rows turn on, 84 degree is an irradiation angle of the used LEDs. The fishing lamp light irradiates up to a distance of 3.3 m from the center of the fishing boat. When the fishing boat is tilted 3 degrees by the roll motion, the light irradiation distance reduces by as much as 11m, and the outer 11m is then in shadow. To compensate this variation, the LED fishing lamp system on the fishing boat against the roll motion of the sea is proposed.

**2.1 Main Control Module**

The objective of the main control module is to collect the operating condition setting of the fishing lamp via input panels and the tilt angle information of a fishing boat from the sensor module. These information are used for controlling each LED module within the fishing lamp module in order to maintain a stationary irradiation region regardless of the tilting of the fishing boat.

The main control module is composed of an input panel, a display panel, a main controller, and a data communication port

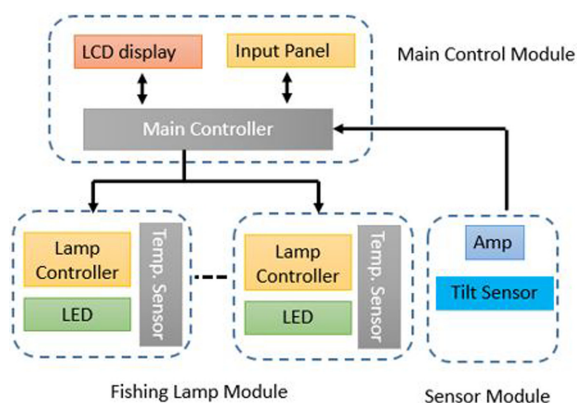

Fig. 1 Composition of an LED fishing lamp system

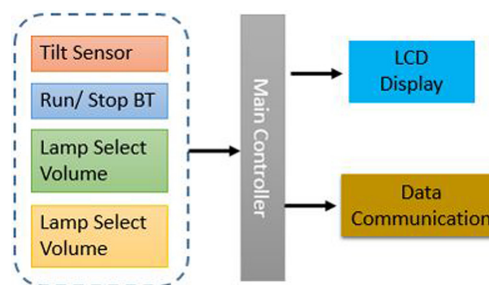

Fig. 2 Configuration and signal flow of the main control module

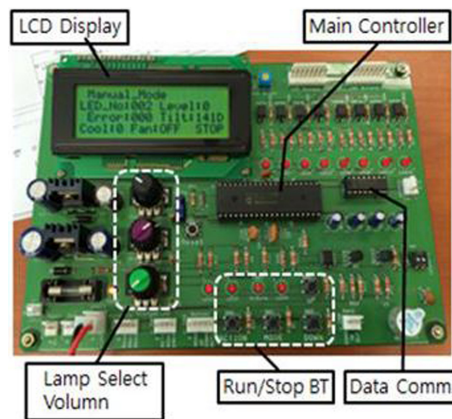

Fig. 3 Fabricated main controller module

shown in Fig. 1. The input panel is used for setting the conditions for operating the fishing lamp system, the display panel shows the status of the system operation and the main controller collects the information needed to control the fishing lamp modules. Information is transmitted to the fishing lamp modules through the data communication port. Figs. 2 and 3 show the configuration and signal flow of the main control module, and the fabricated main control module, respectively.

The fishing lamp system developed in this study largely

operates in three modes. One operation mode operates the entire fishing lamp modules installed on the fishing boat, another operation mode operates only the odd-numbered fishing lamp modules, and the other mode operates only the even-numbered fishing lamp modules. The lamp select volume knob is used for selecting one of these operation modes.

The tilt set volume knob is used for selecting the number of LED module rows, turned on simultaneously in the fishing lamp module. The Run/Stop button is used for turning the entire fishing lamp system on or off. The display panel shows information on the overall operation status of the fishing lamp system such as roll angle, operation mode, LED module operation status of the fishing lamp module, and fishing lamp temperature. The tilt sensor port is used to acquire the tilt angle of the fishing boat measured by the sensor module. The main controller processes the operating conditions of the proposed lamp system and tilt angle, transmitted to the fishing lamp module. That is, the address data representing both the fishing lamp modules to be operated and the LED modules to be tuned on or off in accordance with the tilt angle, etc. are sent to the fishing lamp module.

### 2.2 Fishing Lamp Module

The fishing lamp module is comprised of 22 LED modules, a lamp controller, and a temperature sensor. Each LED module includes 5 LEDs and a LED module driver. LED module and fishing lamp module (in Fig. 4) in this study are  $100.7 \times 13.55 \times 8 \text{ mm}^3$  and  $265 \times 226 \times 68 \text{ mm}^3$ , respectively.

Two LED modules are arranged in 11-LED module rows. Each fishing lamp module is equipped with a lamp controller as seen in Fig. 5. The lamp controller manipulates each LED module row using the information, received from the main controller, dip switch, and temperature sensor. That is, two LED modules arranged in each row are turned on or off at the same time. The dip switch is used for assigning a unique number to each fishing lamp module, and indicates the location (left or right) of the fishing lamp module installed on the fishing boat. The service life of an LED is significantly influenced by the ambient temperature so the developed LED fishing lamp system is controlled by the cooling system. In additions to cooling system, as a back-up protection, the lamp controller is designed to regulate an error of cooling system with temperature sensor embedded on PCB.

Variations in the voltage supplied to an LED also significantly influence the service life of the LED. If the voltage supplied to the LED can be kept constant, the service life of the LED can be extended and the light intensity of an LED can be maintained constant. An LED module driver, a regulator with a Buck function, ADT6780 (AD Tech., Korea), is installed on each LED module.

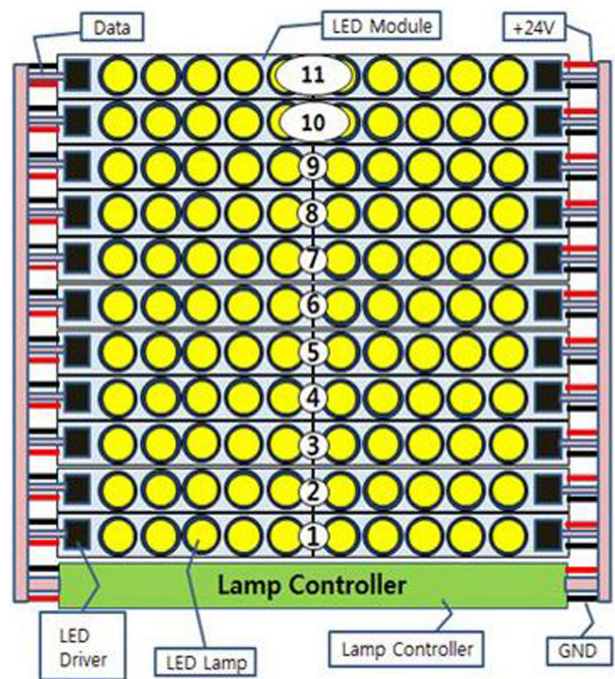

Fig. 4 Composition of a fishing lamp module

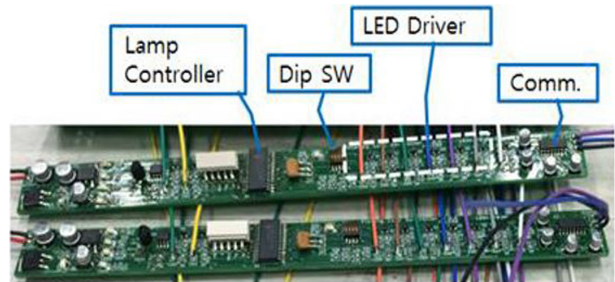

Fig. 5 Fabricated lamp controller

The effective input voltage range of the regulator is DC 18-30 V. The regulator increases input voltage if the input voltage is low, and decreases input voltage if the input voltage is high by using a voltage feedback function to supply a constant voltage to the LED. 5 LEDs are connected in series to construct an LED module.

The pulse with modulation (PWM) terminal receives the command from the LED lamp controller to manipulate the LEDs. In other words, if 5 V is applied to the PWM terminal, the LEDs in the LED module are turned on, and if the power is not applied, the LEDs in the LED module are turned off. The voltage is supplied from the outside through the "Power In" terminal. The LED driver is mounted on the former stage of the shunt register. A coil is used to reduce the ripple of the current flowing through the LEDs.

The 3W-class XLamp XP-G was used as the LEDs. A lens, mounted on the top of the LEDs, is used to reduce the width of the

light emitted from the LED. Irradiation angle of LED used in this study shows a wide field of view angle (124 degree), which is not appropriate for controlling a developed system. To this end, a fishing lamp module is designed to partly overlap irradiation angle of two continued module's row. Therefore, the lens with 21.9 irradiation angle degree mounted on the top of the LEDs was used to easily control the change of the irradiation region due to the roll motion of the fishing boat. Fig. 6 shows the fabricated LED module.

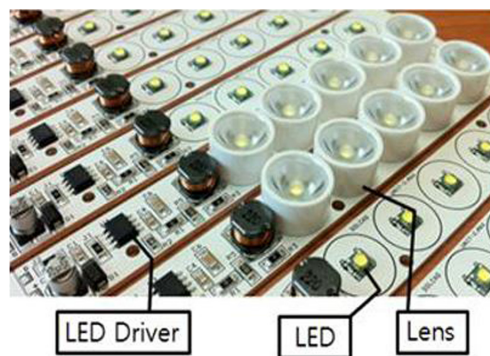

Fig. 6 Fabricated LED module

### 2.3 Sensor Module

A sensor module is composed of an Electronic Bubble Type tilt sensor for measuring the roll angle of the fishing boat and an amplifier for amplifying the sensor signal. The sensitivity of the tilt sensor is 2 mV/deg. The measuring range and the resolution are  $\pm 70$  degree and 0.01 deg., respectively. The response time is less than 0.3 seconds.

When 5 V is supplied to the tilt sensor, 2.5 V is output when the sensor is in an upright position, 2.67 V when tilted 90 degrees to the left, and 2.33 V when tilted 90 degrees to the right. The tilt sensor used generates only a small voltage difference of 2 mV in accordance with a tilt of 1 degree. Thus, a differential amplification module is used to create an output voltage of 2.5 V when the tilt sensor is in an upright position, the output voltage of 0.42 V when the tilt sensor is inclined 90 degrees to the left, and the output voltage of 4.58 V when the tilt sensor is inclined 90 degrees to the right. The output voltage of the differential amplification module is transformed to 0-255 steps using an 8-bit microprocessor. The transformed output voltage is then supplied to the main controller. The main controller converts the output voltage of the sensor module back to a tilted angle, and displays the tilted angle on the display panel.

### 3. Reliability Verification Test

A test was carried out to verify the reliability of the LED module driver, designed to supply a constant voltage to each LED. Another test was also carried out to evaluate the reliability of the tilt sensor module, which is used to measure the roll angle of the fishing boat. The last test was carried out to confirm that the LED modules of the fishing lamp module were controlled reliably in accordance with the roll motion of the fishing boat to maintain a stationary irradiation region. This study considers a general fishing boat, 10,000 kg in weight, 10 m in length, 2.4 m in width, and 1.15 m in depth. In this model, down-flooding angle is 28.44 degree and capsizing angle is no less than down-flooding angle.

Table 1 Reliability test result of the fabricated LED driver

	Input volt (V)	Output volt(V)
1	18	15.53
2	19	15.53
3	20	15.52
4	21	15.49
5	22	15.48
6	23	15.48
7	24	15.47
8	25	15.45
9	26	15.44
10	27	15.43
11	28	15.42
12	29	15.42
13	30	15.41

### 3.1 Fishing Lamp Module

The supply voltage to an LED has a significant effect on the service life of the LED. A LED driver reliability test as shown in Fig. 6 is executed to evaluate a constant supply voltage to the LED. The power supply used for the test supplied a voltage from 18 V to 30 V to the LED driver while increasing the voltage by 1 V. The input voltage to the LED driver was measured at the "Power In" terminal. The output voltage was measured at the output stage of the coil. Table 1 shows the result of the reliability test for the fabricated LED driver. Output voltage was slightly decreased with the increase of the Input voltage. The input voltage to the LED was very stable at  $15.47 \pm 0.06$  V without showing a large variation, even if the external supply voltage showed a large variation of 18-30 V.

### 3.2 Tilt Sensor Module Reliability Test

A test was carried out to verify the reliability of the tilt sensor

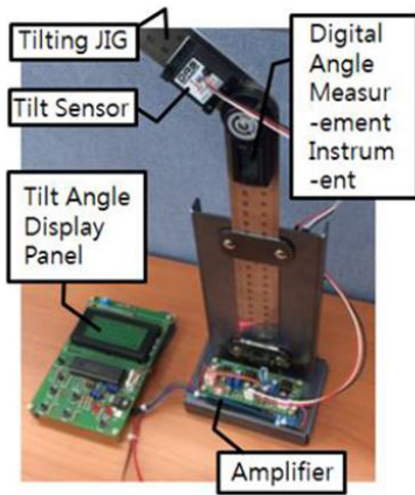

Fig. 7 Angle test bench

Table 2 Comparison of the angle measured with the tilt sensor module and that measured with the digital angle measurement instrument

Left direction		Right direction	
Tilt sensor module	Dig. angle meas. inst.	Tilt sensor module	Dig. angle meas. inst.
0	0	0	0
1	1	1	1
2	2	2	2
3	3	3	3
4	4	4	4
5	5	5	5
6	6	6	6
7	7	7	7
8	8	8	8
9	9	9	9
10	10	10	10
11	11	11	11
12	12	12	12

module. As displayed in Fig. 7 and Table 2, an angle test bench is composed of a tilting jig, a tilt sensor module, and a digital angle measurement instrument. The tilt sensor module and the digital angle measurement instrument were attached to the tilting jig. The tilting jig was made to be manually (step-wised) moved to the left or right. When the tilting jig was tilted manually to the left or right, the tilted angle was measured with the tilt sensor module and the digital angle measurement instrument. The tilt sensor signal was amplified with the differential amplifier. The amplifier output was converted to a digital signal, and the angle measured with the tilt

sensor was then shown in the display panel. The digital angle measurement instrument measured the tilted angle directly. The digital angle measurement instrument has a measuring range of 180 deg. and a resolution of 0.1 deg.

The tilted angle measured with the tilt sensor module was compared with that directly measured with the digital angle measurement instrument to verify the reliability of the tilt sensor module. The test bench was placed on the surface plate. The test was carried out while manually rotating the tilting jig to the left or right. In the test, the rotating angle was increased by 1 degree. Result shows that the tilted angle measured with the tilt sensor module was exactly consistent with the angle measured with the digital angle measurement instrument.

### 3.3 LED Module Lighting Control Reliability Test

In this study, a LED module lighting control reliability test was performed to verify that the developed fishing lamp system works properly for maintaining a stationary irradiation region by the lighting control of LED modules. Rolling frequency on fishing operation in general is approximate 3 Hz, and the developed system can be allowed to controls LED on/off with very fast command signal. Therefore the proposed system has little effect from high frequency rolling condition on fishery operation. Fig. 8 shows the lighting conditions of the LED modules installed on both the left side and right side of the fishing boat when the fishing boat is rolling to the right. In the figure, “roll angle” represents the tilt angle of the fishing boat measured with the tilt sensor module. Numbers 1-11 in the “Module” column represent the LED module row number. That is, number 1 represents the LED module on the surface side of the sea water, and number 11 represents the LED module on the furthest side from the surface of the sea water.

The fishing lamp system is set to simultaneously light up five LED modules using the Tile Set Volume knob. The fishing lamp system is set to light up LED module numbers 4-8 in the range of 0-3 degrees roll angle. It is also set to adjust the LED module to be lit whenever the roll angle of the fishing boat changes by 3 degrees to maintain a stationary irradiation region. When the fishing boat is tilted to the right, for the fishing lamps installed on the right side of the fishing boat, the lower LED modules are turned off and the upper LED module are turned on to maintain a stationary irradiation region. On the other hand, for the fishing lamps installed on the left side of the fishing boat, the upper LED modules are turned off, and the lower LED modules are turned on.

Therefore, as shown in Fig. 8, when a fishing boat is tilted 4-6 degrees to the right, for the fishing lamps installed on the right side of a fishing boat, LED module number 4 is turned off and LED module number 9 is turned on in order to maintain a stationary

Mod-ule	roll angle(deg)				Mod-ule	roll angle(deg)			
	0-3	4-6	7-9	10 ↑		0-3	4-6	7-9	10 ↑
11	□	□	□	□	11	□	□	□	■
10	□	□	□	□	10	□	□	■	■
9	□	□	□	□	9	□	■	■	■
8	■	□	□	□	8	■	■	■	■
7	■	■	□	□	7	■	■	■	■
6	■	■	■	□	6	■	■	■	□
5	■	■	■	■	5	■	■	□	□
4	■	■	■	■	4	■	□	□	□
3	□	■	■	■	3	□	□	□	□
2	□	□	■	■	2	□	□	□	□
1	□	□	□	■	1	□	□	□	□

(a) left

(b) right

Fig. 8 LED modules to be lit in accordance with the roll motion of a fishing boat (■: on, □: off)

irradiation region. On the other hand, for the fishing lamps installed on the left side of the fishing boat, LED module number 3 is turned on and LED module number 8 is turned off. By the same principle, when a fishing boat is tilted 7-9 degrees to the right, for the fishing lamps installed on the right side of the fishing boat, LED module number 5 is turned off, and LED module number 10 is turned on. On the other hand, for the fishing lamps installed on the left side of the fishing boat, LED module number 2 is turned on and LED module number 7 is turned off. In this way, the LED module to be lit is reliably shifted up and down in accordance with the roll motion of the fishing boat. Energy can thus be saved and the irradiation region can be maintained constant by the active turning on and off of the LED modules. Furthermore, each fishing lamp module is partly overlapped so a resolution of actual vertical lighting angle (0.5 degree) can afford to stabilize the irradiation region.

In these days, efficiency of power consumption on fishery ship is very challenging problem, and this challenge affects to the size of a fishing boat in the world. Therefore, instead of using the maximum light intensity of LED, this study focused on the effectiveness of actively stabilizing the irradiation region against contrast fluctuation using a part of the developed LED modules.

**4. Conclusion**

In this paper, an LED fishing lamp system was developed to maintain a stationary irradiation region despite ship rolling motions. The fishing lamp system is comprised of three modules: main control module, fishing lamp module, and sensor module. In the reliability verification test of the LED module driver, the LED module driver maintained a stable voltage. An angle test bench

was undertaken for the reliability verification test of the tilt sensor module. The tilted angle measured with the sensor module was exactly consistent with the angle measured with the digital angle measurement instrument. Finally, an LED module lighting control test was performed to verify that the developed fishing lamp system works properly in accordance with the roll motion of a fishing boat. In future, the proposed system will be verified with experimental test under a sea environment.

**REFERENCES**

1. Arakawa, H., Choi, S., Arimoto, T., and Nakamura, Y., "Relationship between Underwater Irradiance and Distribution of Japanese Common Squid Under Fishing Lights of a Squid Jigging Boat," Fisheries Science, Vol. 64, No. 4, pp. 553-557, 1998.
2. Choi, S.-J., "Characteristics of Spectral Irradiance Based on the Distance from the Light Source and Operating Method for Fishing Lamps with a Combined Light Source," Korean Journal of Fisheries and Aquatic Sciences, Vol. 42, No. 6, pp. 711-720, 2009.
3. Inada, H. and Arimoto, T., "Trends on Research and Development of Fishing Light in Japan," Journal of the Illuminating Engineering Institute of Japan, Vol. 91, No. 4, pp. 199-209, 2007.
4. Seo, J.-N., An, H.-C., and Kim, D.-H., "Estimating the Economic Effectiveness of Led Fishing Light Systems for the Squid Jigging Fishery," Journal of the Korean Society of Fisheries Technology, Vol. 48, No. 4, pp. 346-351, 2012.
5. An, Y.-I., "Fishing Efficiency of High Capacity (360 w) Led Fishing Lamp for Squid Todarodes Pacificus," Journal of the Korean Society of Fisheries Technology, Vol. 50, No. 3, pp. 326-333, 2014.
6. Choi, S.-K., Kim, S.-J., Park, D.-W., Kil, G.-S., Choi, C.-Y., et al., "Design and Fabrication of an Energy Saving Led-Fishing Lamp," Journal of the Korean Society of Marine Engineering, Vol. 34, No. 4, pp. 515-521, 2010.
7. Shen, S. and Huang, H., "Design of Led Fish Lighting Attractors Using Horizontal/Vertical LIDC Mapping Method," Optics Express, Vol. 20, No. 24, pp. 26135-26146, 2012.
8. Lee, M., "Fixing Device of LED Fishing Lamp," KR Patent, 10-1069892, 2011.
9. Lee, S., "Light Control Apparatus of a Fishing Lamp Using LED," KR Patent, 10-1370382, 2014.
10. Hong, J.-H., Park, S., Park, S.-S., and Ryoo, C.-K., "Aiming Point Correction Technique for Ship-Launched Anti-Air Missiles Considering Ship Weaving Motion," Journal of Institute of Control, Robotics and Systems, Vol. 20, No. 1, pp. 94-100, 2014.